

Fill in the circle next to the correct answer.

1.

Which number is equal to  $10^4$ ?

- (A) 100
- (B) 1,000
- (C) 10,000
- (D) 100,000

2.

Connor is buying tickets to a concert. The concert he and his friends want to see costs \$4.75 per ticket. Connor has \$26.00 total.

What is the **greatest** number of tickets Connor can buy?

- (A) 4
- (B) 5
- (C) 6
- (D) 7

3.

$$\frac{2}{7} + \frac{1}{3} =$$

- (A)  $\frac{3}{10}$
- (B)  $\frac{3}{21}$
- (C)  $\frac{1}{7}$
- (D)  $\frac{13}{21}$

4.

Jasmine solves the equation  $\square \div 4 = 363$  using this area model.

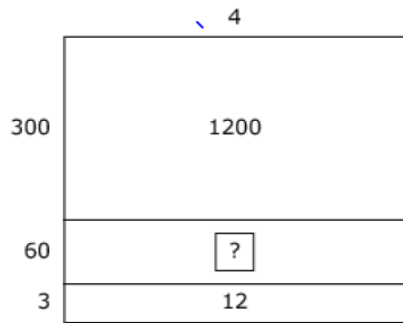

Which statement explains how Jasmine should solve for the missing number in the model?

- Ⓐ Jasmine should divide 60 by 4.
- Ⓑ Jasmine should divide 1200 by 12.
- Ⓒ Jasmine should multiply 3 times 60.
- Ⓓ Jasmine should multiply 4 times 60.

5.

Triangle  $ABC$  is graphed in the coordinate plane.

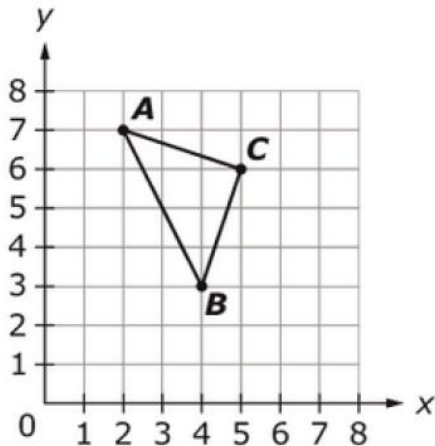

Which set of ordered pairs shows the coordinates of points  $A$ ,  $B$ , and  $C$ ?

- Ⓐ  $A(2, 7), B(4, 3), C(5, 6)$
- Ⓑ  $A(2, 7), B(5, 6), C(4, 3)$
- Ⓒ  $A(7, 2), B(3, 4), C(6, 5)$
- Ⓓ  $A(7, 2), B(4, 3), C(5, 6)$

6.

Susan has 4 gallons of juice. How many cups of juice does she have?

- Ⓐ 16 cups
- Ⓑ 8 cups
- Ⓒ 64 cups
- Ⓓ 32 cups

7.

Use this rectangle to solve the problem.

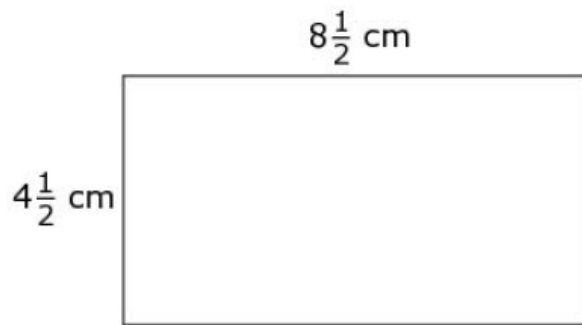

What is the area, in square centimeters, of the rectangle?

- Ⓐ  $32\frac{1}{4}$
- Ⓑ  $32\frac{1}{2}$
- Ⓒ  $38\frac{1}{4}$
- Ⓓ  $38\frac{1}{2}$

8.

Walter puts 1050 cubic inches of dirt into the tank shown. What is the height of the dirt in the tank?

- (A) 5 inch
- (B) 21 inches
- (C) 2 inches
- (D) 210 inches

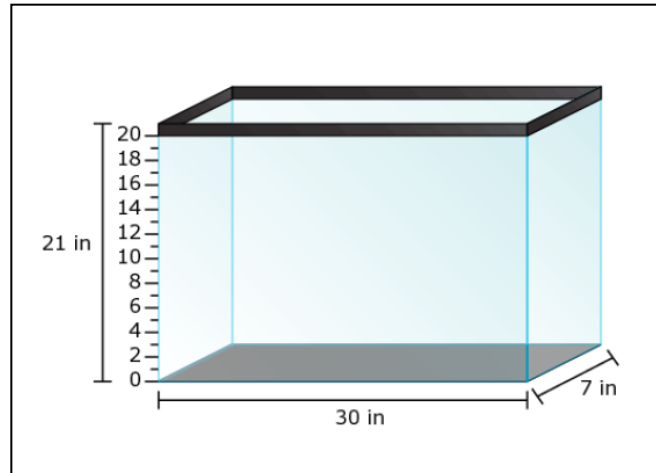

9.

Jason begins at the start of a path and rides his bike  $11\frac{1}{2}$  miles on the path. The path is  $12\frac{1}{4}$  miles long. How far must Jason travel to reach the end of the path?

- (A)  $23\frac{3}{4}$  miles
- (B)  $\frac{1}{2}$  mile
- (C)  $\frac{3}{4}$  mile
- (D)  $11\frac{1}{2}$  miles

10.

Jen measured the growth of a sunflower.

- In week one, it grew  $2\frac{1}{2}$  inches.
- In week two, it grew  $2\frac{3}{4}$  inches.
- In week three, it grew  $3\frac{1}{4}$  inches.

How much did the sunflower grow over all three weeks?

- (A)  $5\frac{3}{4}$  in
- (B)  $7\frac{1}{2}$  in
- (C) 8 in
- (D)  $8\frac{1}{2}$  in

11.

Lola has 4 orange juice containers. Each container is  $\frac{5}{8}$  full.

Lola claims to have a total of  $2\frac{1}{2}$  gallons of orange juice in the 4 containers.

Which of these statements **must** be true in order for Lola's claim to be correct?

- (A) Each container has a capacity of  $\frac{5}{8}$  gallon.
- (B) Each container has a capacity of 1 gallon.
- (C) Each container has a capacity of  $2\frac{1}{2}$  gallons.
- (D) Each container has a capacity of 8 gallons.

**Read each question carefully and solve.**

12.

Tyler is 8 years old. His sister Olivia is 4 years less than twice his age.

Write a numerical expression for Olivia's age.

13.

Select **all** expressions that are equal to  $3\frac{1}{4}$ .

- $26 \times \frac{1}{8}$
- $2\frac{1}{8} \times 2$
- $4 \times 13$
- $\frac{1}{4} \times 3$
- $13 \times \frac{1}{4}$

14.

Select two fractions that can be rewritten with a denominator of 24.

$\frac{1}{6}$

$\frac{1}{5}$

$\frac{5}{7}$

$\frac{9}{10}$

$\frac{1}{9}$

$\frac{7}{8}$

15.

The right rectangular prism shown has a length of 6 centimeters, width of 3 centimeters, and height of 4 centimeters.

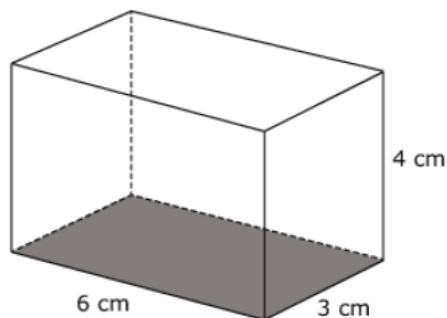

Determine whether each equation can be used to find the volume ( $V$ ) of this prism. Select Yes or No for each equation.

	Yes	No
$V = 18 \times 4$	<input type="checkbox"/>	<input type="checkbox"/>
$V = (6 + 3) \times 4$	<input type="checkbox"/>	<input type="checkbox"/>
$V = 6 \times 3 \times 4$	<input type="checkbox"/>	<input type="checkbox"/>
$V = 9 \times 4$	<input type="checkbox"/>	<input type="checkbox"/>

16.

Put one number into each box to create a fraction that correctly completes each statement.

$$4 \times \frac{\square}{\square} < 4$$

$$4 \times \frac{\square}{\square} = 4$$

$$4 \times \frac{\square}{\square} > 4$$

17.

The location of Mary's home is plotted on the coordinate grid.

Read these clues about other places in Mary's town.

- The bank is located at (9, 1).
- The library is 6 blocks from the store.
- The store is 3 blocks from the park.
- The hospital is 5 blocks from the library.
- The park is 4 blocks from Mary's home.

Label the names of each place to the correct location on the coordinate grid.

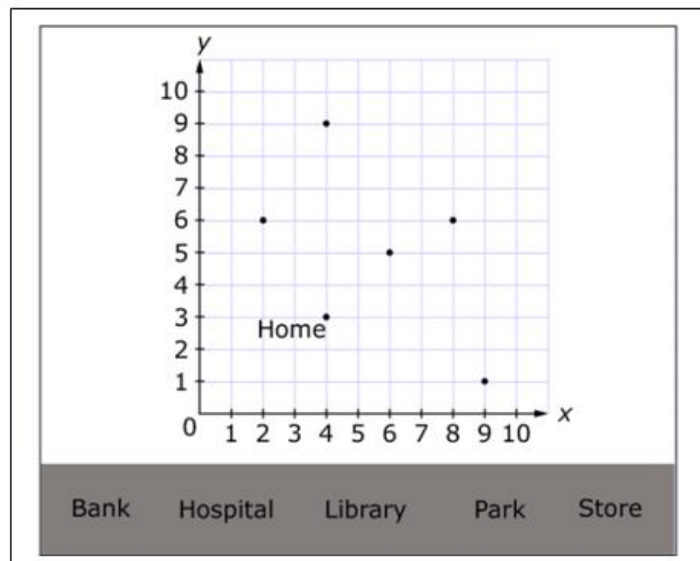



Key  
— represents 1 block

18.

All parallelograms have opposite sides that are equal in length and parallel.

Determine whether each polygon shown is also a parallelogram.

Select Yes or No for each polygon.

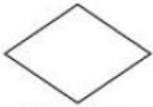
	Yes	No
 Rectangle	<input type="checkbox"/>	<input type="checkbox"/>
 Trapezoid	<input type="checkbox"/>	<input type="checkbox"/>
 Rhombus	<input type="checkbox"/>	<input type="checkbox"/>

19.

Use this pentagon to solve the problem.

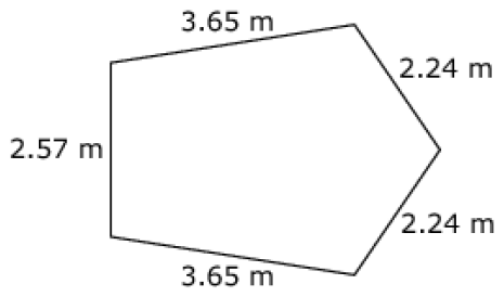

Enter the perimeter, in **centimeters**, of the pentagon.

20.

Enter a value for  $b$  that makes this statement true:  $5 \times b$  is less than 5 but greater than 0.